

Governors State University

OPUS Open Portal to University Scholarship

All Capstone Projects

Student Capstone Projects

Fall 2019

Online Art Gallery

Vineesha Tharikonda

Follow this and additional works at: <https://opus.govst.edu/capstones>

For more information about the academic degree, extended learning, and certificate programs of Governors State University, go to http://www.govst.edu/Academics/Degree_Programs_and_Certifications/

Visit the [Governors State Computer Science Department](#)

This Capstone Project is brought to you for free and open access by the Student Capstone Projects at OPUS Open Portal to University Scholarship. It has been accepted for inclusion in All Capstone Projects by an authorized administrator of OPUS Open Portal to University Scholarship. For more information, please contact opus@govst.edu.

ONLINE ART GALLERY

By

VINEESHA THARIKONDA

Governors State University
1 University Pkwy, University Park, IL 60484

GRADUATE CAPSTONE SEMINAR PROJECT

Submitted in partial fulfillment of the requirements

For the Degree of Master of Science,

With a Major in Computer Science



Governors State University
University Park, IL 60484

2019

ABSTRACT

Online Art Gallery in an e-commerce website designed and developed for people to connect with art and artists all over the world. This website enables people to discover and shop enormous selection of artworks, paintings, drawings, prints, and provides an opportunity for artists to showcase and sell their artwork.

This website allows people to browse exclusive art galleries of different famous and best-selling artists along with a feature to sign up for special offers to buy. This website provides artists to view and monitor their artwork sales activities. This Online Art Gallery website includes a database which stores and manages all artists' data, art gallery data, artwork sales data, customers' data, order history and tracking details.

Table of Content

1	<i>Project Description</i>	1
1.1	Competitive Information	1
1.2	Relationship to Other Applications/Projects	1
1.3	Assumptions and Dependencies	1
1.4	Future Enhancements	1
1.5	Definitions and Acronyms	1
2	<i>Project Technical Description</i>	1
2.1	Application Architecture	2
2.2	Application Information flows	2
2.2.1	Data flow diagram	2
2.2.1.1	Admin	2
2.2.1.2	Artist	3
2.2.1.3	Customer	4
2.3	Use Case Diagram	4
2.4	Sequence Diagram	5
2.4.1	Admin	6
2.4.2	Artist	7
2.5	Interactions with other Applications	7
2.6	Capabilities	7
2.7	Risk Assessment and Management	7
3	<i>Project Requirements</i>	8
3.1	Identification of Requirements	8
3.2	Operations, Administration, Maintenance and Provisioning (OAM&P)	9
3.3	Security and Fraud Prevention	9
3.4	Release and Transition Plan	9
4	<i>Project Design Description</i>	9
4.1	Database Design	9
4.2	ER Relation Diagram	11
5	<i>Internal/external Interface Impacts and Specification</i>	11
6	<i>Design Units Impacts</i>	11
6.1	Functional Area A/Design Unit A	11
6.1.1	<i>Functional Overview</i>	11
6.1.2	<i>Impacts</i>	11
6.1.3	<i>Requirements</i>	12
6.1.3.1	Functional Requirements	12
6.1.3.2	Non-Functional Requirements	13
7	<i>Open Issues</i>	13
8	<i>Acknowledgements</i>	13
9	<i>References</i>	13
10	<i>Appendices</i>	14
10.1	Registration	14
10.2	Login	15
10.3	Home	15
10.4	Products	16
10.5	Admin – Change Password	17
10.6	Admin – Add Product	17
10.7	Admin- Edit/Delete Product	18
10.8	Admin – Artists	19
10.9	Admin- Customers	19
10.10	Admin- Orders	20
10.11	Cart	21

1 *Project Description*

Online Art Gallery is a web-based application. The users will be able to Register & Login into the website as an Artist or a Customer. Artist can upload his/her art works into the website and same can be purchased by the customer. Artist can see the list of customers, orders and order details. Artist can also upload Arts. Artist can update the orders as soon as it delivered to the customer. Customer can browse and purchase the arts from different artists. Customer can also see the list of orders which have ordered by him/her. Administrator will have the full control over the website. Administrator can manage the Arts, Artists, Customers, and Orders. Artist and Customer users can change their password. However, Administrator can change the password of anyone in the system.

1.1 *Competitive Information*

OAG application is similar to other products in the market. However, it's providing the Cash on Delivery option as one of the pay modes for the Buyers.

1.2 *Relationship to Other Applications/Projects*

OAG application does not have any relationship with other applications and all required information stored in the OAG database not from any other resources.

1.3 *Assumptions and Dependencies*

These are the assumptions which are made for the safe functioning and implementation of the project.

- We primarily designed our project to be user-friendly with good user navigation.
- Proper authentication is used in the project to ensure no intruders can access the sensitive data.

1.4 *Future Enhancements*

Product delivery tracking functionality will be incorporated with current application. Single sign on functionality will be implemented. This means users can use their Gmail, Facebook or Microsoft account to login into the application. Our future enhancements include secure payment gateway integration so that customers pay through third party websites.

1.5 *Definitions and Acronyms*

OAG – Online Art Gallery – It's a web application and great platform for Artists to upload their arts and sell them. Customers also will get benefit by browsing through the gallery with thousands of arts from different artist and can buy the same.

2 *Project Technical Description*

Visual Studio 2019 Community version and MS SQL Express is used to develop the web application where C# .Net is used to connect with database and perform business logics. Asp.net web forms are used to design the user interface.

2.1 Application Architecture

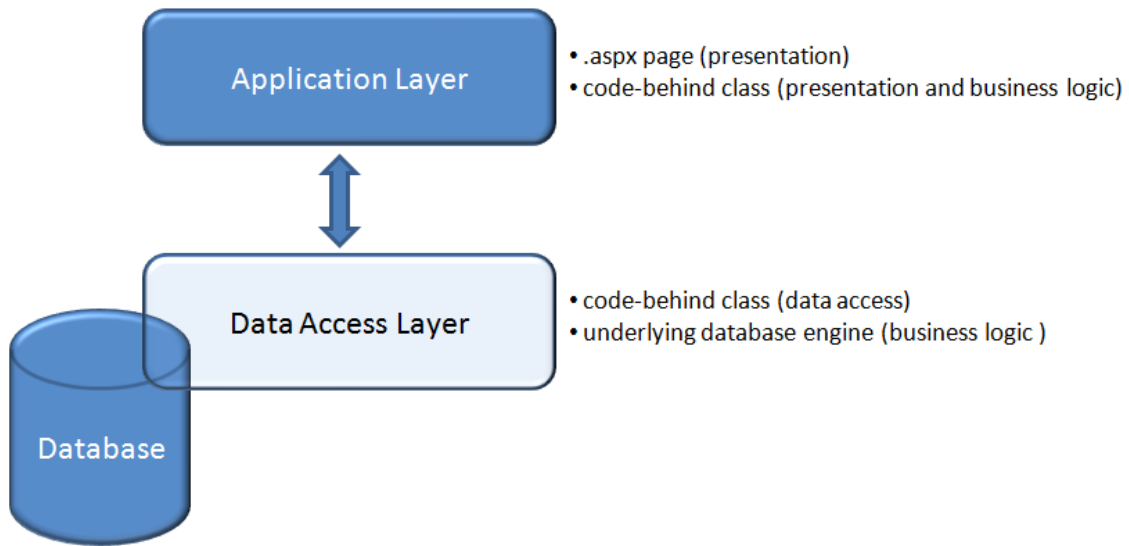

Figure 1 Application Architecture

2.2 Application Information flows

OAG has three types of users

- Admin
- Artist
- Customer (Buyer)

2.2.1 Data flow diagram

2.2.1.1 Admin

Admin has the full control over the application. Admin can manage the Artists, Customer, Products, and Orders.

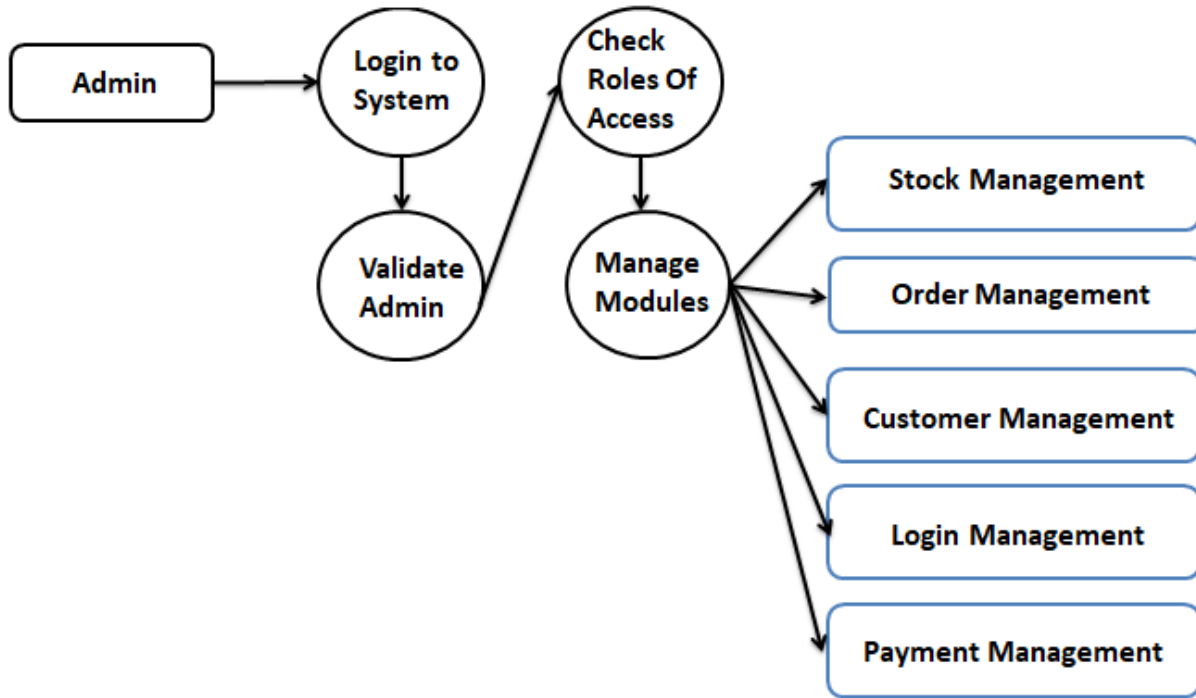

Figure 2 Data Flow Diagram for Admin

2.2.1.2 Artist

Artist can upload the new arts into the application, exhibit his arts and sell them to customers. Artist can update order status.

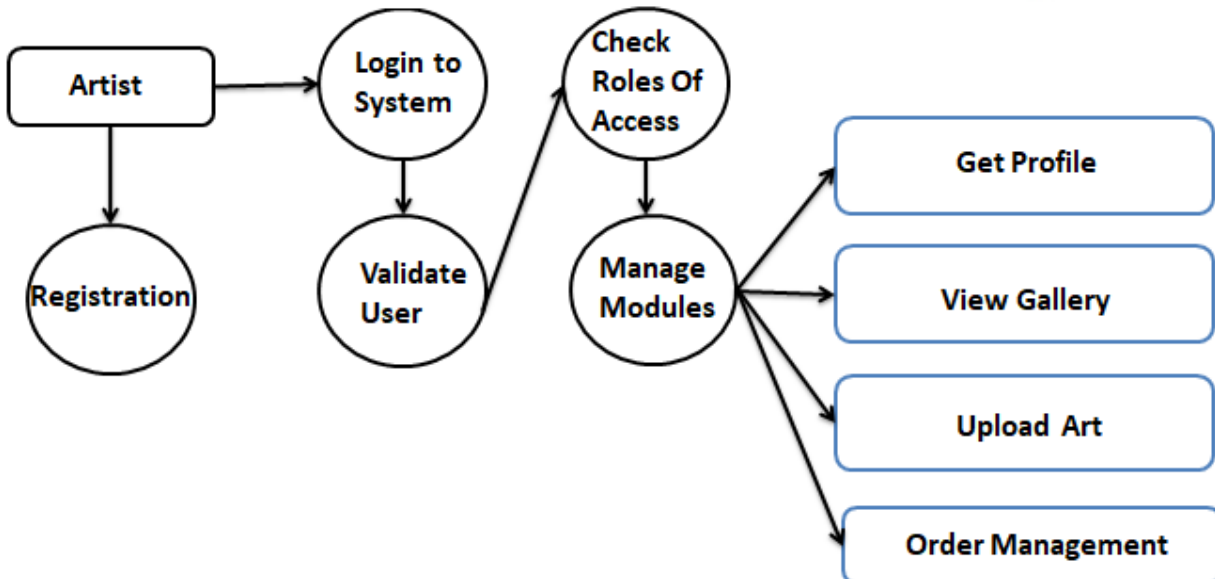

Figure 3 Data Flow Diagram for Artist

2.2.1.3 Customer

Customer can browse the different category arts and place the order.

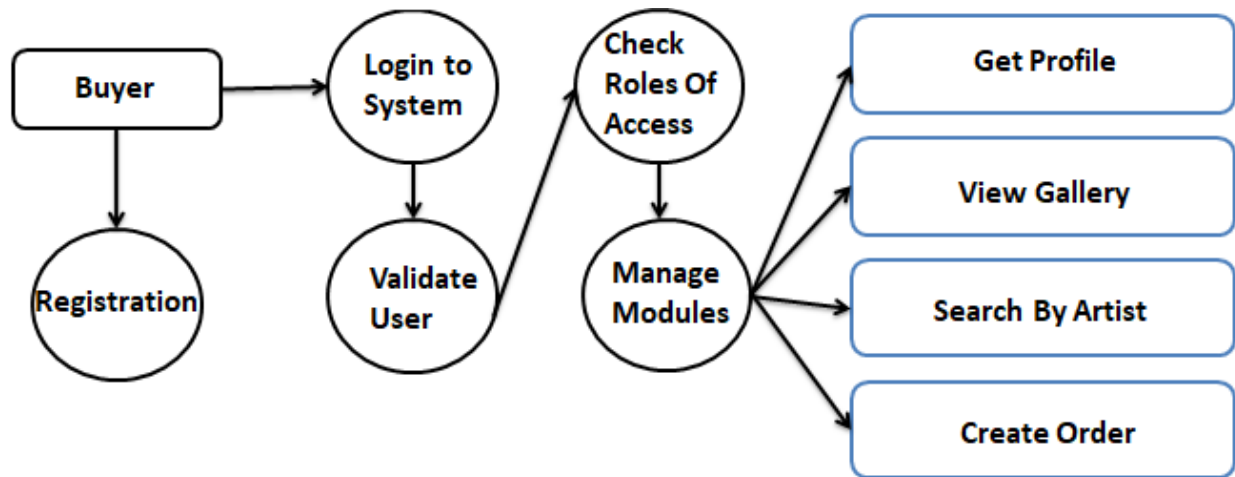

Figure 4 Data Flow Diagram for Customer

2.3 Use Case Diagram

The relationship between and among the actors and the use cases of OAG

- Admin – Use cases of admin are Login, Log out, User management, Manage Arts, Manage Buyers
- Artist – Use cases of Artist are Login, Log out, Manage orders, Manage Art stock
- Buyer (Customer) – Use cases of customer are Login, Log out, Change password, Create order, Create order, Make payment

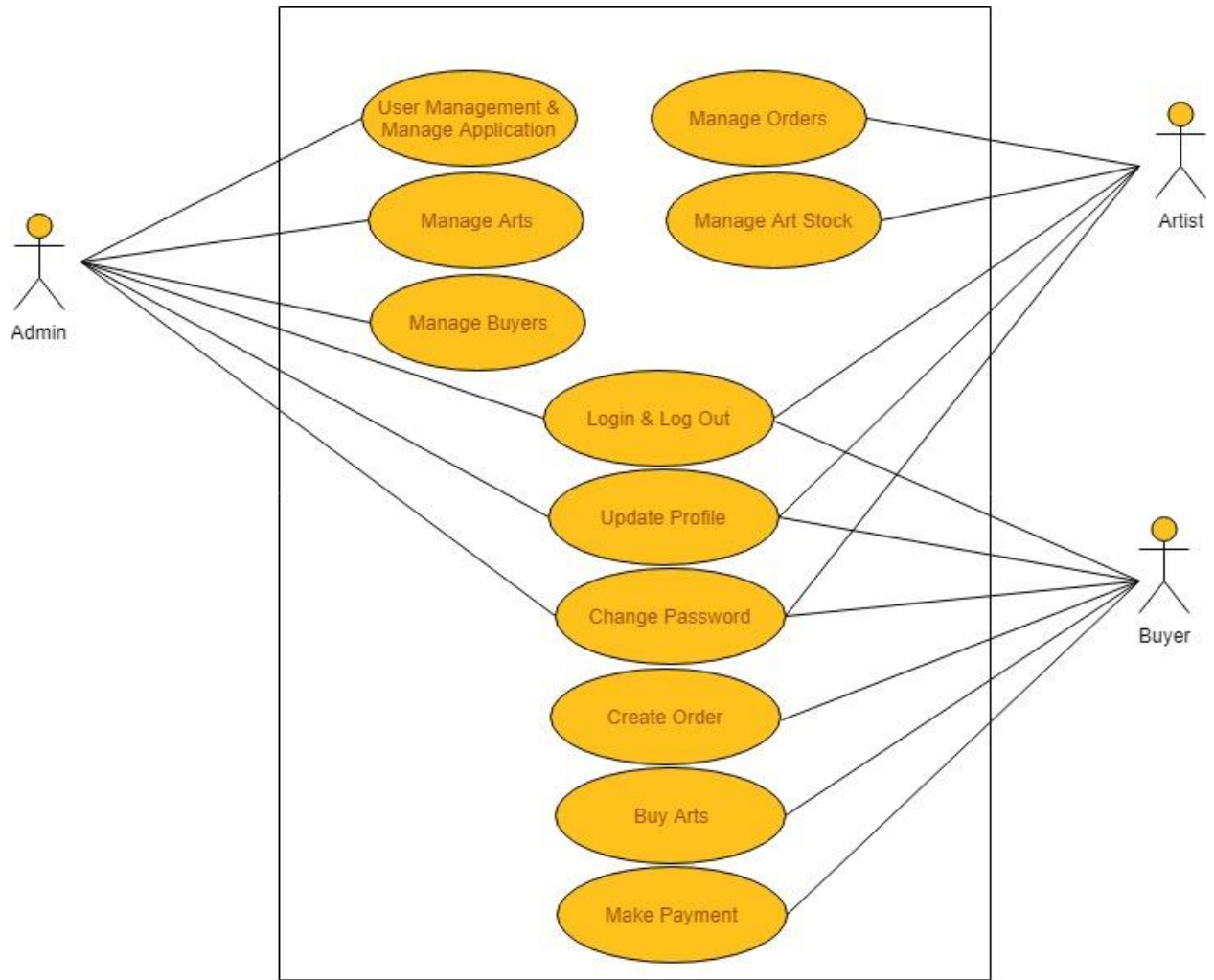

Figure 5 OAG – Usecase Diagram

2.4 Sequence Diagram

Below UML Sequence diagram of OAG shows the interaction between the objects Login, Art Management, Artist/Buyer Management, and Order Management.

2.4.1 Admin

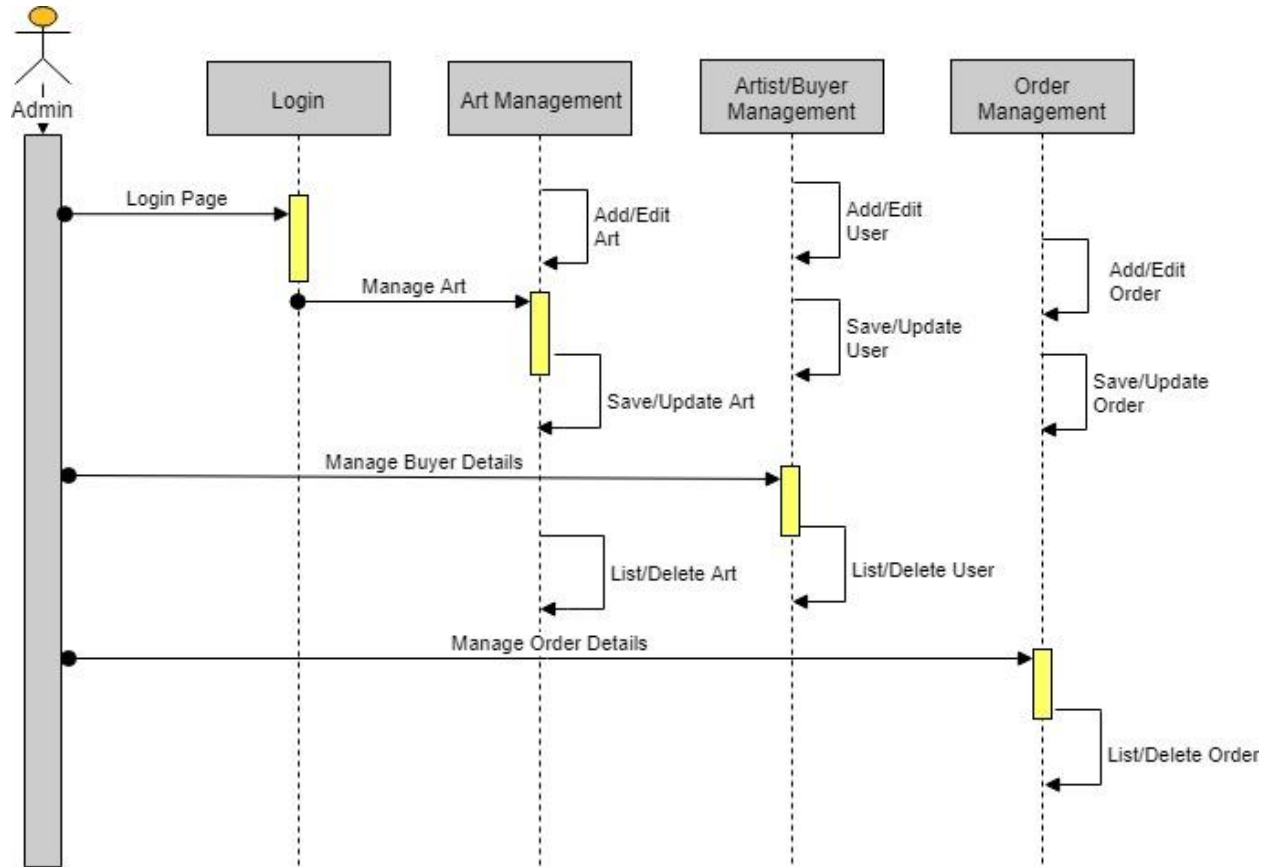

Figure 6 Sequence Diagram - Admin

2.4.2 Artist

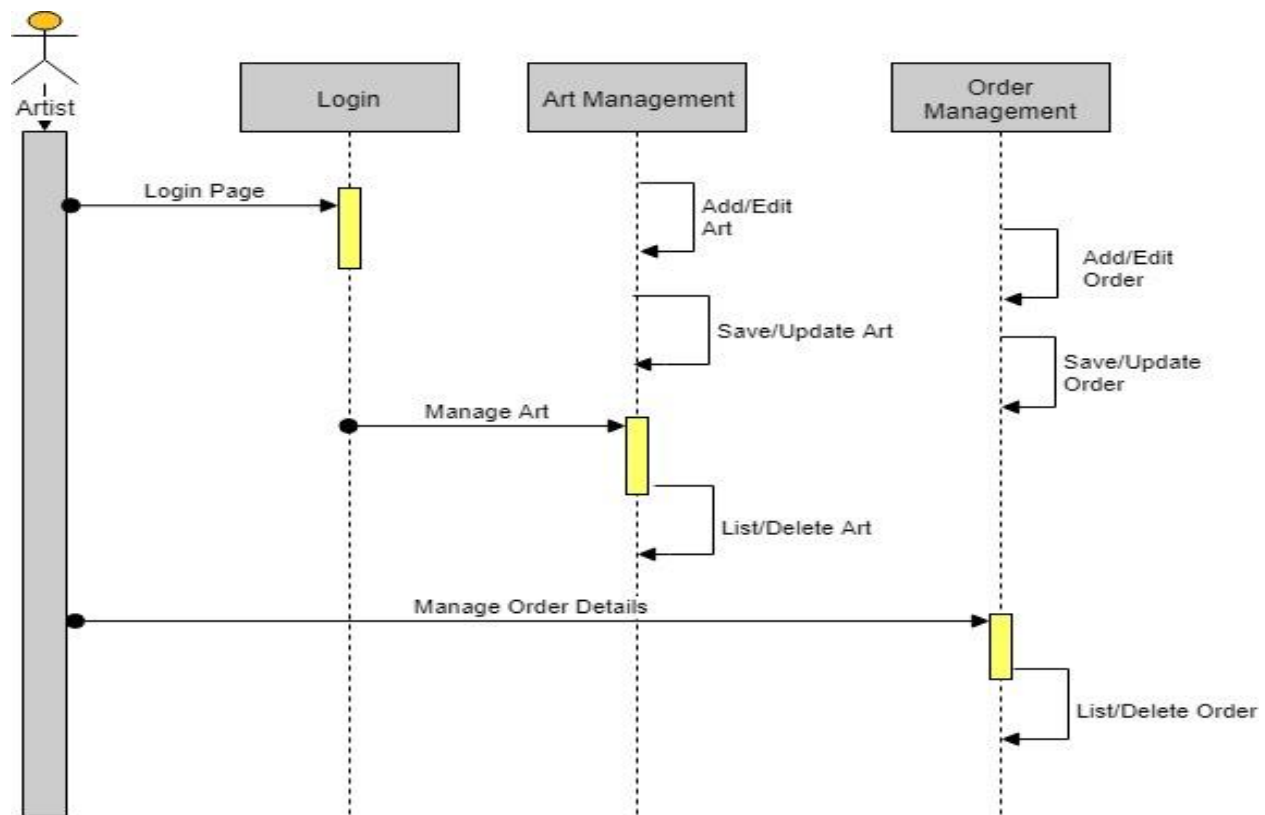

Figure 7 Sequence Diagram - Artist

2.5 Interactions with other Applications

As the primary functionality of the application is to upload arts, sell the arts. Apart from this the application does not need any information from any other resources where all the data that is needed by the application will be gathered during the creation of the new Art either it might be a user or an art.

2.6 Capabilities

The below are the few actions that can be performed by the Admin/Artist/Customer.

Action	Admin	Artist	Customer
Create Art	Yes	Yes	No
Edit/Delete Art	Yes	Yes	No
Change Password	Yes	Yes	Yes
Update Order	Yes	Yes	No
Search Arts	Yes	Yes	Yes

2.7 Risk Assessment and Management

The main risk is to secure customer payment information. However, as per standards security codes are not saving into the database. Another one is storing the user login credentials. User login credentials are not saving in plain text instead we are using hashing algorithms.

3 Project Requirements

3.1 Identification of Requirements

<OAG-1 User-Registration-0001>

OAG allows user to register them self as Artist/Customer

OAG allows user to register as an Artist or a Customer. While registration user has to enter mandatory personnel information, which will be saved into the database for further transactions.

<OAG-1 User-Login-0002>

OAG allows login the user as Admin/Artist/Customer

OAG allows user to login into the application as an Admin, an Artist or a Customer. While logging in, system will validate the user credentials and access roles. Application will display the menu items with respect to logged in user role.

<OAG-1 Brose Gallery-0003>

OAG allows user to browse the gallery

OAG allows users to browse the Arts Gallery by categories, by subjects, by artists, and by prices. Each art will have Name & Price. On top of the results, system displays the text box. User enters the any keywords to filter out the results.

<OAG-1 Change Password-0004>

OAG allows user to change their passwords

OAG allows Artists/Customer to change their password. In order to change the password, user has to give the new password & confirm password. User can use their new password right after they changed the password successfully. Admin can change the password for anyone.

<OAG-1 Upload Art-0005>

OAG allows Artist to upload the Arts

OAG allows an Artists to create/edit/delete their arts. While creating the new art, Artist has to give the Art name, description, unit price and image of the art. Admin can upload the art on behalf of any artists.

<OAG-1 Upload Art-0006>

OAG allows Artist to upload the Arts

OAG allows an Artists to create/edit/delete their arts. While creating the new art, Artist has to give the Art name, description, unit price and image of the art. Admin can upload the art on behalf of any artists.

<OAG-1 Add to Cart-0007>

OAG allows Customer to add products to Cart

OAG allows a customer to search & add products to cart. Before placing the order customer can see the list of products added to cart. Customer can remove or update the quantity of any one of the cart items.

<OAG-1 Place Order-0008>

OAG allows Customer to place the order

OAG allows a customer to place the order. Customer can select the pay mode as **Cash on Delivery** or Card payment.

<OAG-1 Update Order-0009>

OAG allows an Admin/Artist to update the order

OAG allows an Admin/Artist to update order status to complete on after successfully delivered to the customer.

<OAG-1 Display Artists/Customers-0010>

OAG allows displays Artists/Customers

Admin user able to see the list of Artists/Customers details in administration page.

3.2 Operations, Administration, Maintenance and Provisioning (OAM&P)

OAG application can be accessible by three user roles i.e. Admin, Artist, and Customer. All user roles have Login, Log out and Change password functions. Admin user have full control over the application. Artist user has mainly manage his/her arts, manage orders functionalities. Customer user has Browse and place order functionalities.

3.3 Security and Fraud Prevention

Users login credentials hashed and stored into the database. Website allows only authorized users into the application. OAG application server and database has securely stored in sever and maintained by network administrators. These servers can be accessible by only network administrators.

3.4 Release and Transition Plan

As present the application is not online and can be accessed only within the local system. In future the application will be made online by which everyone will be able to access the application irrespective of the geological location.

4 Project Design Description

4.1 Database Design

The below is the database design diagram that contains the list of all the tables that have been used in the web application and the relationships that are present between them.

- The details of Arts are store into the Arts tables
- Each table contains primary key and unique keys.
- The entity Orders has relationship with Order Items, User tables
- There is one-to-one and one-to-many relationships available between Orders, Arts, Users

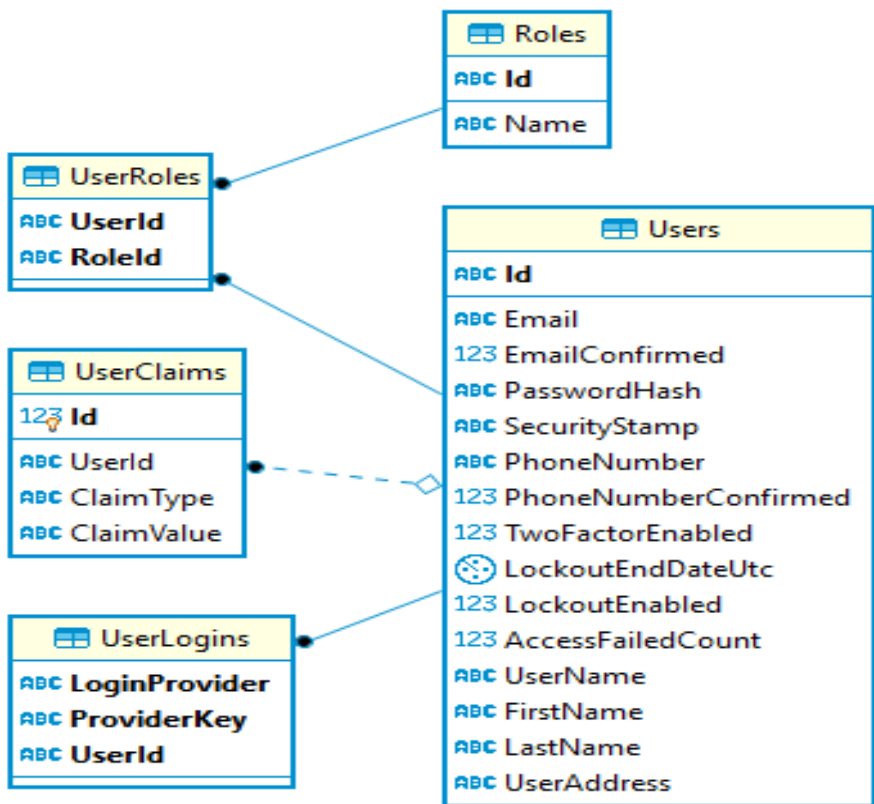

Figure 8 Users Database Diagram

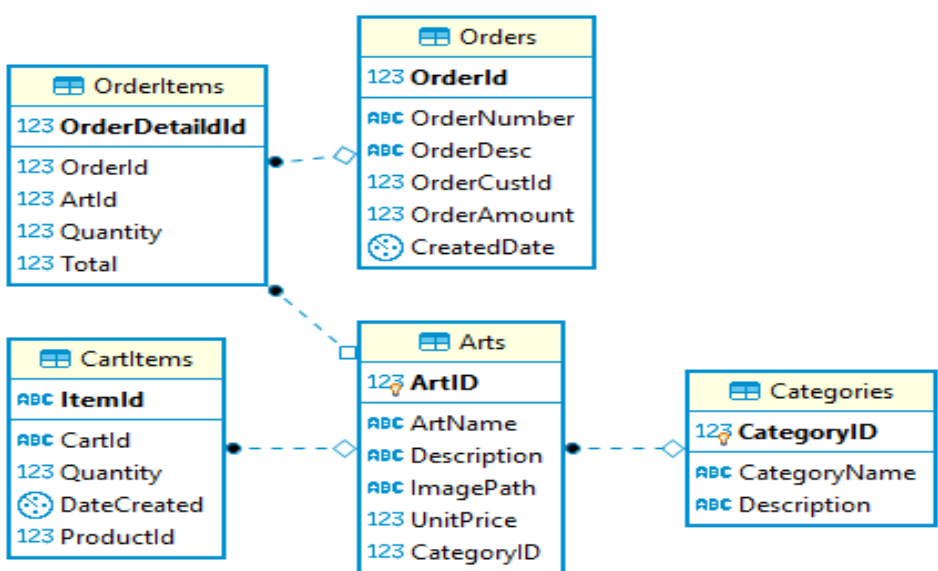

Figure 9 Transaction tables Database Diagram

4.2 ER Relation Diagram

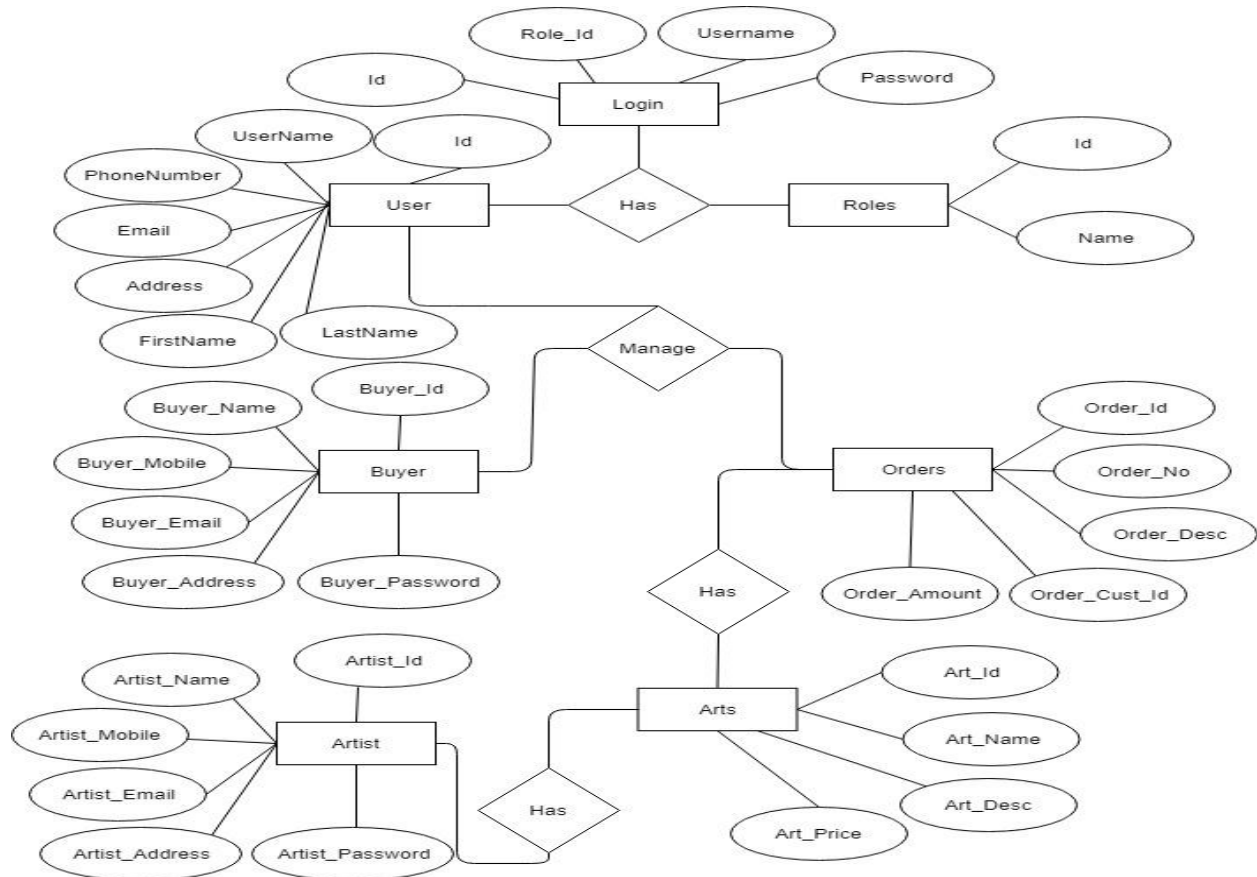

Figure 10 ER Relation Diagram

5 Internal/external Interface Impacts and Specification

In OAG web application, there is no interaction with the third-party servers or applications. The OAG application saves the user data into database and uses the same further user actions.

6 Design Units Impacts

6.1 Functional Area A/Design Unit A

6.1.1 Functional Overview

- OAG application can be accessed by three roles i.e. Admin, Artist, and Customer.
- Admin user has the full control over the application. Admin can change the password of any user, can manager products, can manage the orders.
- Artist users can manager their arts, update the orders
- Customer users can search the products and place the order

6.1.2 Impacts

No Impacts

6.1.3 Requirements

6.1.3.1 Functional Requirements

- User browses the Arts Gallery by categories
- By default, Home page (Dashboard) displays the arts.
- Each art will have Name & Price.
- There are few search parameters to filter out the result by the user.
 - a) **Category** - On top of the results, system displays the category buttons. User can select any specific category to filter out the result.
 - b) **Name/Description** - On top of the results, system displays the text box. User enters the any text to filter out the results.
 - c) **Artists** – On top of the results, system displays the text box. User enters the any artist name to filter out the results.
 - d) **Price** – On top of the results, system displays the dropdown with different price options. User select the dropdown option to filter out the results **Ex:-** Dropdown options are \$0-\$50, \$50-\$100 etc.,
- Three user roles are defined in the system. Those are Artist, Customer and Admin.
 - a) An **Artist** is a user and will publish/ demonstrating the arts.
 - b) **Customer** is a user and can purchase arts.
 - c) **Admin** serves as an administrator of the website and can manage artists, buyers, and orders.
- On successful registration, user can log in to the website. In order to login into the website, user should provide the valid username (Email) and password in the login page.
- System validates the user credentials, check the roles of access, and displays the modules with respect to the user role.
- Customer can add arts into the cart. User can see the all items which are added to cart from Cart menu.
- Shopping cart displays the table with all the cart items with ID, Name, Quantity, Price columns. System allows user to perform following action in the shopping cart.
- Update – User can increase/decrease the quantity of the cart items.
- Remove – User can remove the any cart item from the cart.
- From shopping cart – Buyer checkout the cart items and continue through selection of pay mode and confirm the payment details.
- If user can confirm the order, then system displays the confirmation message when order creation is successful. System generates the unique order number.
- Customer can select any one of the below payment types while confirming the order.
 - a) Cash on Delivery – Buyer can place the order and pay the cash when order delivers.
 - b) Debit/Credit Card – Buyer can select the card payment. Buyer should enter the card number, Name on the card, Expiry date and CVV number. System encrypts the customer cards information and save into the database using cryptography.
- System allows the **Artist** to publish the arts. While publishing the art, Artist should give the mandatory product information like Category, Name, Description, Price and Art image file etc.,
- System allows the **Artist** to remove the added products. **Artist** can remove only his/her products.

6.1.3.2 Non-Functional Requirements

- **Performance** - OAG website based on web and must be run from the web server. Initial load time will be depending on the internet connection strength and also dependent upon the hardware components of the user.
- **Scalability** - The system should be able to scale up to 500 concurrent users (if there is a need in the future) by installing additional hardware components.
- **Reliability & Availability** - OAG website shall have an ISP with 99.99% uptime availability through their network services.
- **Security** - Client user's web browsers shall never display their password. It shall always be echoed special characters representing typed characters. The back-end database shall only store the hashed version of the user's password. The product back-end servers shall only be accessible to authenticated administrators. A secure server will be required to ensure confidentiality of customer's credit card and other details.
- **Usability** – User can change the password themselves without depend on administrator to reset/change. Add/Update products will allow the Artist to keep on update the product information.
- **Portability** - The system should be portable to various operating environments with minimal downtime.
- **Integrity** – The OAG database shall be backed up once per a week to prevent data loss.
- **Manageability** - The system should be maintained by IT experts and should be allow them to troubleshoot if any problems arise.

7 *Open Issues*

No Open Issues

8 *Acknowledgements*

This Project is created and developed with our own knowledge and documented by ourselves. I really appreciate our Professor Alex Liu who helped us in completing this whole project.

9 *References*



CPSC 8985 FA'19 -
Online Art Gallery Pr

For Visual Studio tool download

<https://visualstudio.microsoft.com/downloads/>

For code Development

<https://docs.microsoft.com/en-us/>

<https://www.c-sharpcorner.com/>

<https://forums.asp.net/>

<https://www.codeproject.com/>
<https://stackoverflow.com/>

10 Appendices

10.1 Registration

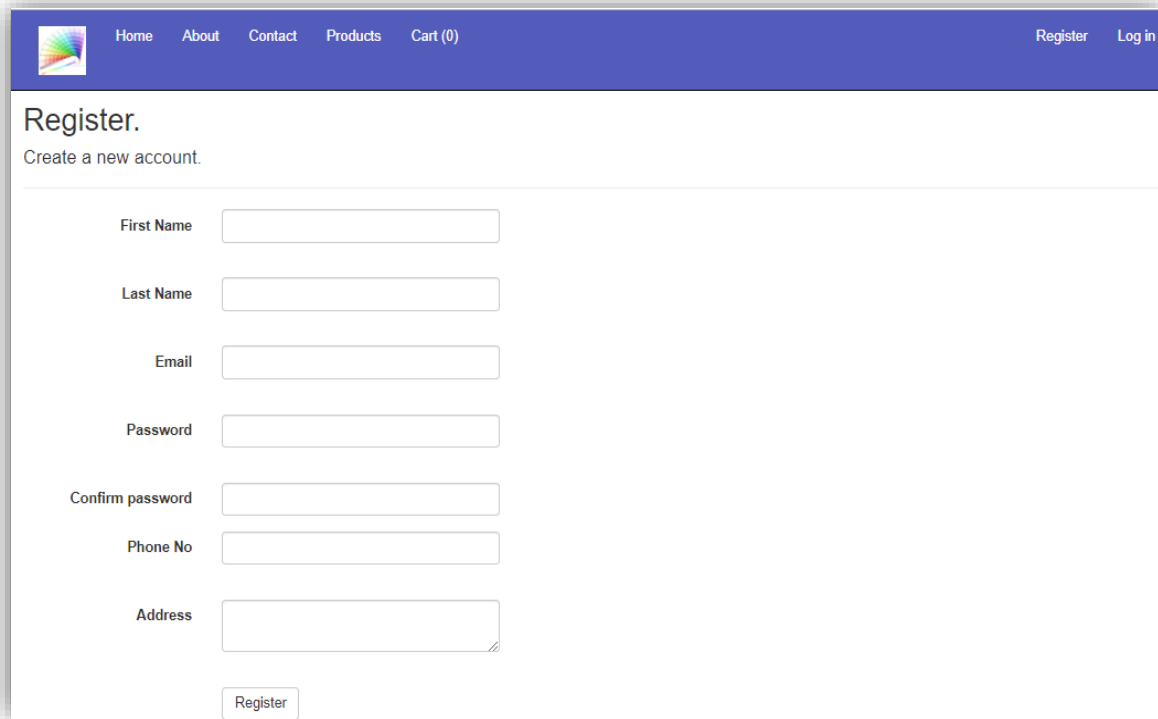

The image shows a web browser window displaying a registration page. The page has a blue header bar with a logo on the left and navigation links: Home, About, Contact, Products, Cart (0), Register, and Log in. Below the header, the main content area is white and contains the following text and form elements:

Register.
Create a new account.

First Name

Last Name

Email

Password

Confirm password

Phone No

Address

Figure 11 Registration Page

10.2 Login

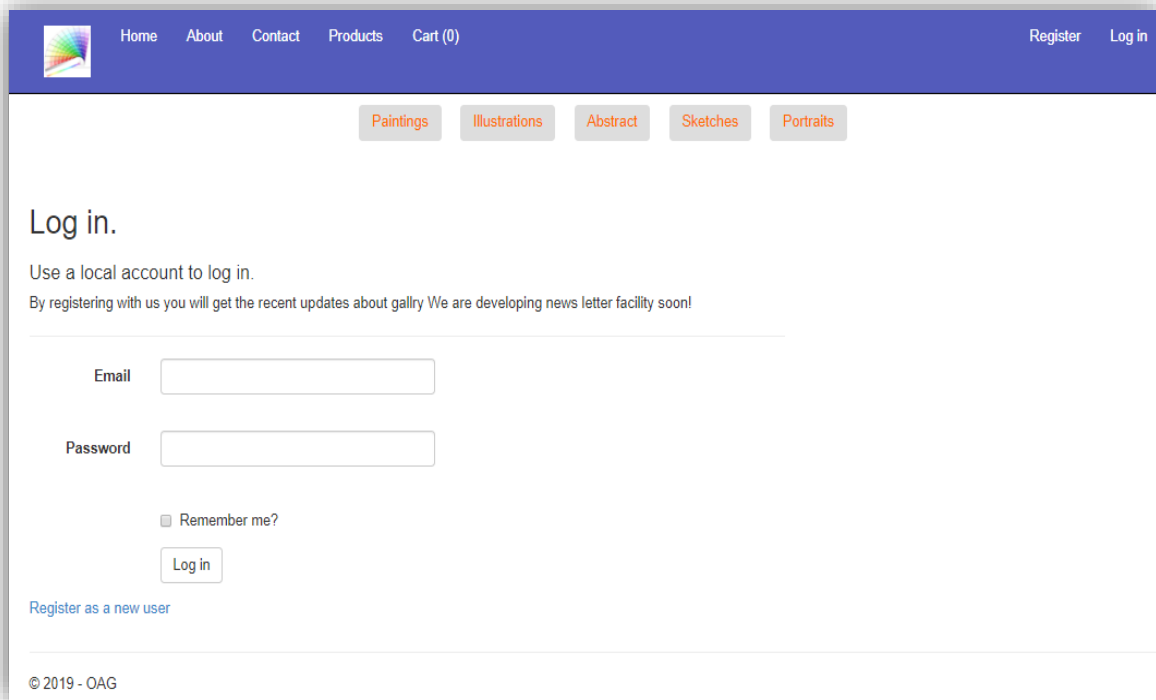

The screenshot shows the login page of an online gallery. At the top, there is a blue navigation bar with a logo on the left and links for Home, About, Contact, Products, and Cart (0) in the center. On the right side of the bar are links for Register and Log in. Below the navigation bar, there are five category buttons: Paintings, Illustrations, Abstract, Sketches, and Portraits. The main content area is titled "Log in." and includes the text "Use a local account to log in." and "By registering with us you will get the recent updates about gallery We are developing news letter facility soon!". There are two input fields for Email and Password, a checkbox for "Remember me?", and a "Log in" button. A link for "Register as a new user" is located below the login form. At the bottom left, the copyright notice "© 2019 - OAG" is displayed.

Figure 12 Login Page

10.3 Home

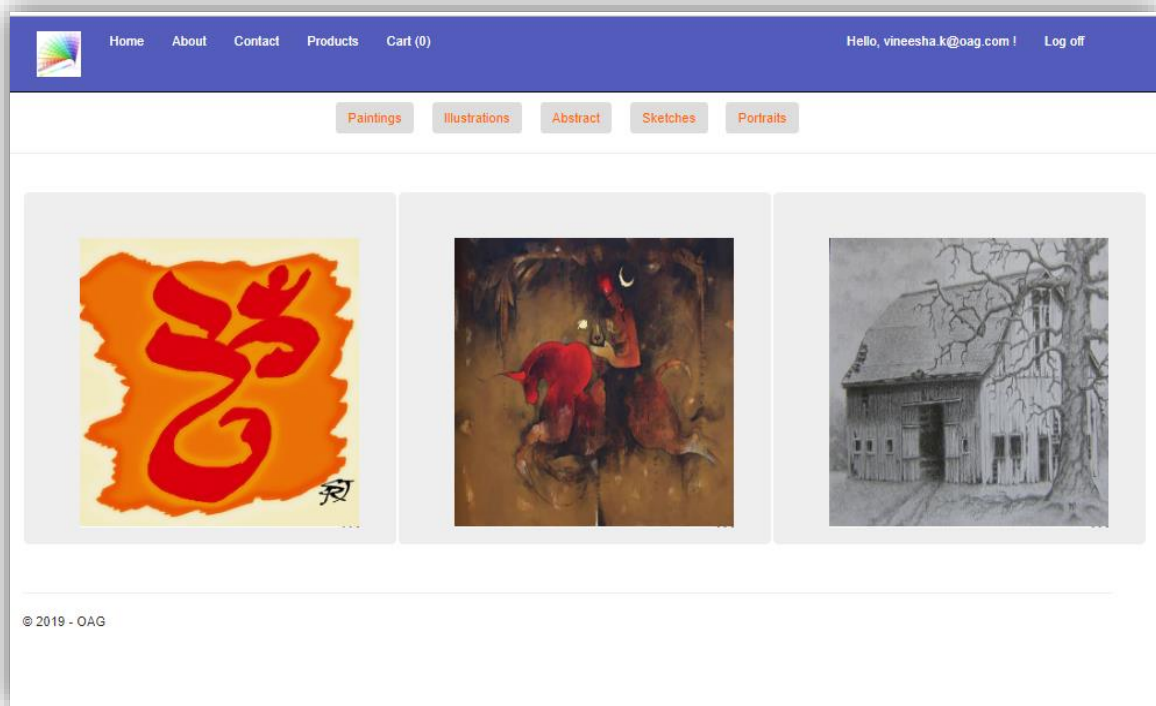

Figure 13 Home Page

10.4 Products

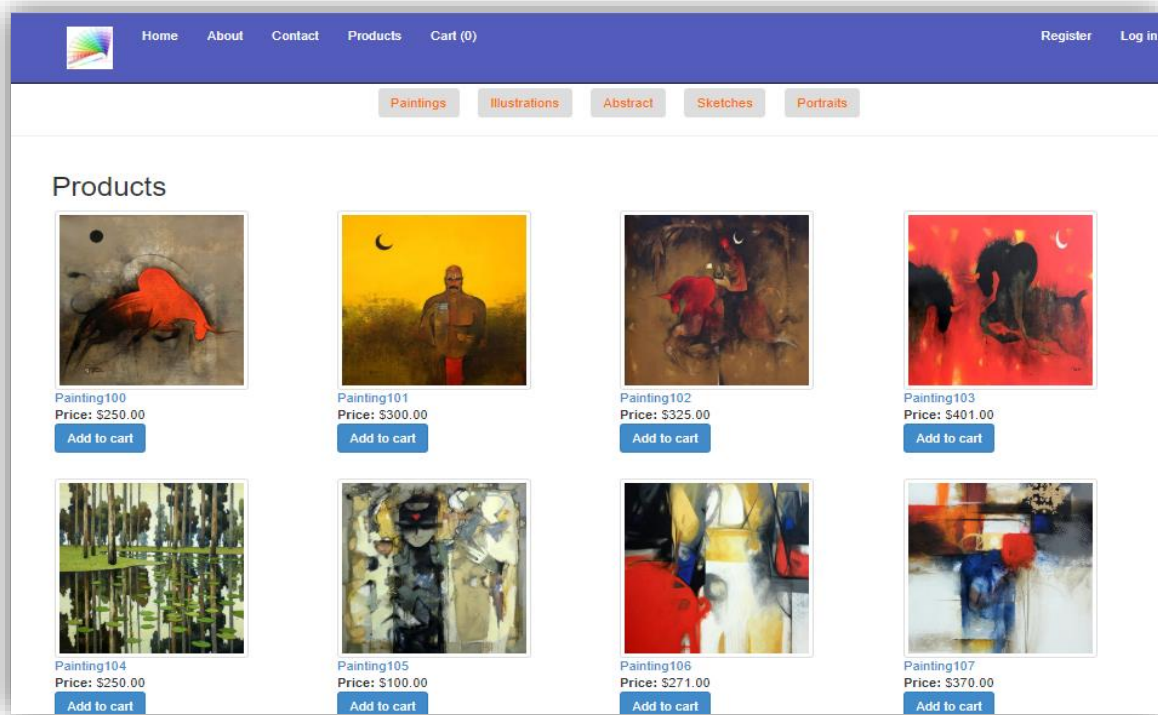

Figure 14 Products Page

10.5 Admin – Change Password

Admin Home About Contact Products Cart (0) Hello, admin@oag.com | Log off

Change Password

Enter your new password.

Email

Password

Confirm password

Reset

Add Product

Edit / Delete Products

Artists

Customers

Orders

© 2019 - OAG

Figure 15 Admin - Change Password Page

10.6 Admin – Add Product

Admin Home About Contact Products Cart (0) Hello, admin@oag.com | Log off

Change Password

Add Product

Category:

Name:

Description:

Price:

Image File: No file chosen

Artist:

Add Product

Edit / Delete Products

Artists

Customers

Orders

Figure 16 Admin – Add Product Page

10.7 Admin- Edit/Delete Product

Change Password

Add Product

Edit / Delete Products

Artist: All

	Category	Name	Description	Price	Image File	Artist	
Delete	Paintings	Painting100	Acrylic on canvas By Mr. Amol Pawar	\$250.00		One Artist	Edit
Delete	Paintings	Painting101	Acrylic on canvas By Mr. Amol Pawar	\$300.00		One Artist	Edit
Delete	Paintings	Painting102	Acrylic on canvas By Mr. Amol Pawar	\$325.00		One Artist	Edit
Delete	Paintings	Painting103	Acrylic on canvas By Mr. Amol Pawar	\$401.00		One Artist	Edit
Delete	Paintings	Painting104	water color art by Mr. Sundar Swami	\$250.00		One Artist	Edit
Delete	Paintings	Painting105	Acrylic on canvas By Mr. Jitendra Patel	\$100.00		One Artist	Edit
Delete	Paintings	Painting106	Free-form painting by Mr S. Iyer	\$271.00		One Artist	Edit

Figure 17 Admin – Edit/Delete Product Page

10.8 Admin – Artists

Admin Home About Contact Products Cart (0) Hello, admin@oag.com! Log off

Paintings Drawings Prints Sculpture Photography

Change Password

Add Product

Edit / Delete Products

Artists

Last Name	First Name	Email	Address	Phone Number
K	Vineesha	vineesha.k@oag.com	chicago	1234567890
One	Artist	artistone@oag.com	USA	1234567890
Two	Artist	artisttwo@oag.com	USA	1234567890

Customers

Orders

Figure 18 Admin – Artists Page

10.9 Admin- Customers

Admin Home About Contact Products Cart (0) Hello, admin@oag.com! Log off

Paintings Drawings Prints Sculpture Photography

Change Password

Add Product

Edit / Delete Products

Artists

Customers

Last Name	First Name	Email	Address	Phone Number
One	Customer	customerone@oag.com	USA	1234567890
Three	Customer	customerthree@oag.com	USA	1234567890
Two	Customer	customertwo@oag.com	USA	1234567890

Orders

© 2019 - OAG

Figure 19 Admin – Customers Page

10.10 Admin- Orders

The screenshot shows the Admin Orders page. At the top, there is a navigation menu with links: Admin, Home, About, Contact, Products, and Cart (0). The user is logged in as 'admin@oag.com!' and can click 'Log off'. The sidebar on the left contains menu items: Change Password, Add Product, Edit / Delete Products, Artists, Customers, and Orders. The main content area displays a table of orders. Order 1 is completed, and Order 2 is in processing. Order 2 is expanded to show a detailed list of products, including Photography, Sculpture, Prints, and Paintings, with columns for Category, Product Name, Description, Quantity, Unit Price, Total, and Artist.

Order Id	Ordered By	Order Date	Order Total	Status		
+ 1	One Customer	11-10-2019 17:56	\$158.00	Completed	Edit	
- 2	Two Customer	11-10-2019 21:10	\$1,404.00	In Processing	Edit	
Category	Product Name	Description	Quantity	Unit Price	Total	Artist
Photography	Portrait107	Portrait by community artist	1	\$269.00	\$269.00	Two Artist
Sculpture	Sketch103	Pencil sketch from our community artist	1	\$300.00	\$300.00	Two Artist
Prints	Abstract101	The Abstract Art by community Artist	1	\$321.00	\$321.00	Two Artist
Prints	Abstract102	The Abstract Art by community Artist	1	\$264.00	\$264.00	Two Artist
Paintings	Painting100	Acrylic on canvas By Mr. Amol Pawar	1	\$250.00	\$250.00	One Artist
+ 3	Three Customer	11-10-2019 21:26	\$1,157.00	In Processing	Edit	

Figure 20 Admin – Orders Page

10.11 Cart

The screenshot shows a web application's shopping cart page. At the top, there is a navigation bar with links for Home, About, Contact, Products, and Cart (2). On the right side of the navigation bar are links for Register and Log in. The main heading is "Shopping Cart". Below the heading is a table with the following data:

ID	Name	Price (each)	Quantity	Unit Price	Item Total	Remove Item
3	Painting102	\$325.00	<input type="text" value="1"/>	\$325.00	\$325.00	<input type="checkbox"/>
18	Abstract101	\$321.00	<input type="text" value="1"/>	\$321.00	\$321.00	<input type="checkbox"/>

Below the table, the text "Order Total: \$646.00" is displayed. There is an "Update Cart" button. The payment section includes radio buttons for "Cash on Delivery" and "Debit/Credit Card" (which is selected). Under "Debit/Credit Card", there are radio buttons for "Type of Card": "Visa" (selected), "Master Card", "American Express", and "PayPal". There are input fields for "Card Number" and "Security Code". The "Expiry" section has dropdown menus for the month (set to "Jan") and the year (set to "2019"). A "Place Order" button is located at the bottom of the payment section.

Figure 21 Cart Page